

3/4" & 1" Self-Priming Utility Pumps

Model 2851-96

**Model 2851-96
Aluminum**

- Aluminum Construction
- Viton® Mechanical Seal and O-Ring
- 1" NPT Suction and Discharge Ports
- 1/3 HP ODP Motor with 8 Ft. 115 VAC Power Cord
- Two Garden Hose Adapters and Carry Handle Included
- Self-Cleaning Impeller
- Maximum Suction Lift 15 Ft. Without Foot Valve

AMT Model 2851-96 is designed for liquid transfer and general dewatering such as: emergency water supply, storm drains, pool/spa tub drainage and select chemical transfer up to 1.6 specific gravity that are compatible with all pump components.

Model 4292-96

**Model 4292-96
Cast Aluminum**

- Cast Aluminum Construction
- Buna-N Mechanical Seal and O-Ring
- 1" NPT Suction and Discharge Ports
- Two Garden Hose Adapters and Carry Handle Included
- 1/2 HP NEMA 56J Open Drip Proof (ODP) Motor with 8 Ft. 115 VAC Cord
- Maximum Suction Lift 6 Ft.

AMT Model 4292-96 is designed to be portable and handle many water transfer services including: storm drainage, emergency water supply, wash down and pool/spa tub draining. Self-cleaning, semi-open impeller handles solids up to 1/8" diameter.

**Model 4850-97
Cast Bronze**

Model 4850-97

- Cast Bronze Construction
- Buna-N Mechanical Seal and O-Ring
- 3/4" NPT Suction and Discharge Ports
- 1/8 HP, 12 Volt DC, 3700 RPM Motor
- Maximum Suction Lift 4 Ft.

The AMT Model 4850-97 Self-priming Bronze Centrifugal pump is compact and designed for a wide range of dewatering/recirculating applications including: marine, salt water aquaculture and live well tanks. Meets U.S. Coast Guard (USCG) Electrical Standards (Title 33, Chapter 1, Part 183, Subpart 1) for Ignition Protection on Gasoline Powered Vessels.

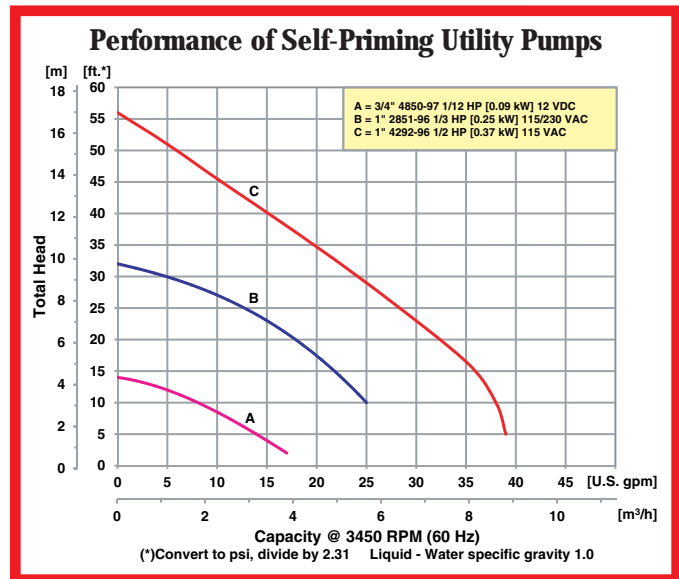

To order, visit
<http://www.pumpstoreusa.com/store/utilitypumps/>
 or call 515-223-4144

Pump Dimensional & Specification Data

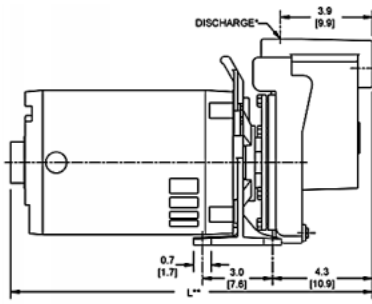

Model 4292-96

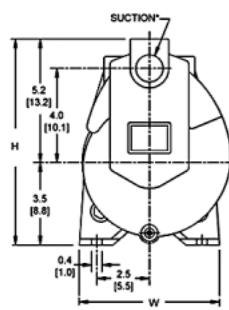

Model 2851-96

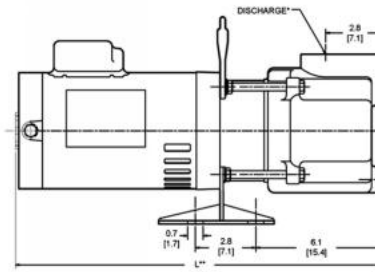

Model 4850-97

Model	Curve	HP	PH	ENC	Voltage @ 60 Hz	Full Load Amps	SUC*	DIS*	L**	W	H	Ship Wt. (Lbs.)
4850-97	A	1/8	-	TENV	12.8V DC	11	3/4	3/4	8.7 [22.0]	4.0 [10.1]	5.1 [12.9]	9
2851-96	B	1/3	1	ODP	115/230	8/4	1	1	17.6 [44.7]	6.0 [15.2]	9.8 [24.8]	39
4292-96	C	1/2	1	ODP	115	10	1	1	16.1 [40.8]	6.5 [16.5]	8.7 [22.0]	30

(*) Standard NPT (Female) pipe thread.

(**) This dimension may vary due to motor manufacturer's specifications.

NOTE: Dimensions are in inches (centimeters) and have a tolerance of $\pm 1/4"$.

Standard Features

Model 4292-96

- Cast Aluminum Construction
- Buna-N Mechanical Seal and O-ring
- 1" NPT Suction and Discharge Ports
- Maximum Working Pressure 75 PSI
- 1/2 HP NEMA 56J Open Drip Proof (ODP) Motor with 8 Ft. 115 VAC Power Cord
- Maximum Temperature 180° F
- Maximum Suction Lift 6 Ft.
- (2) NPT Garden Hose Adapters and Carry Handle Included
- QSP – Quick Ship Pump

Model 2851-96

- Aluminum Construction
- Viton® Mechanical Seal and O-ring
- 1" NPT Suction and Discharge Ports
- Maximum Working Pressure 75 PSI
- 1/3 HP Open Drip Proof (ODP) Motor with 8 Ft. 115 VAC Power Cord
- Maximum Temperature 180° F
- Self-cleaning Impeller
- Maximum Suction Lift 15 Ft.
- (2) NPT Garden Hose Adapters, Base and Carry Handle Included
- QSP – Quick Ship Pump

Model 4850-97

- Cast Bronze Construction
- Buna-N Mechanical Seal and O-ring
- 3/4" NPT Suction and Discharge Ports
- Maximum Working Pressure 50 PSI
- 1/8 HP, 12 Volt DC Motor
- Maximum Temperature 180° F
- Maximum Suction Lift 4 Ft.
- QSP – Quick Ship Pump

Hazardous Duty/Explosion Proof motors available from stock ranging from 1 to 10 HP; CALL FOR QUOTATION & LEAD TIME!