

Submersible Shredder Sewage Pump



- Cast Iron with Stainless Steel Motor Housing
- Carbide Tipped Shredder Impellers
- Spiral Shredder Mechanism Plate Surface Hardened for Enhanced Cutting Ability
- Triplex Seal System: Double Mechanical Seals Plus Shaft Seal
- Lower Seal - Silicon Carbide
- 115, 230 or 460 VAC @ 60 Hz Available
 - 1 to 5 Horsepower
 - 2", 3" or 4" NPT
 - UL/CSA Listed
 - Single or Three Phase Available

Model 5765-95

AMT Submersible Shredder Sewage pumps feature an enhanced spiral shredder mechanism plate and carbide tipped impeller to prevent clogging and reduce maintenance when cutting through stringy, fibrous and sludge type waste. Applications include: sewage pumping stations, septic tanks, sewage treatment plants, dirty water drainage, flood and emergency. Motors are rated continuous duty and single phase models have thermal overload protection. **Minimum liquid requirements must be above 85%. Failure to do so may cause pump damage and void warranty.**

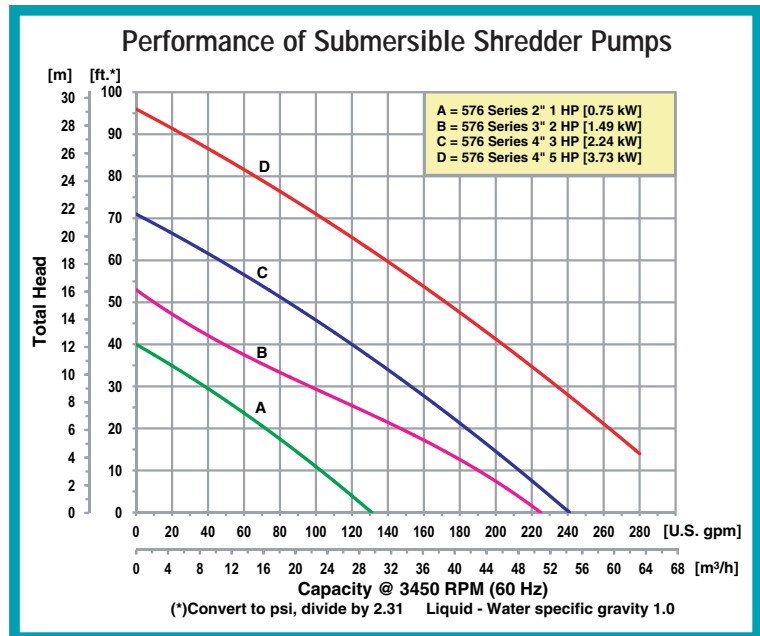

To order, visit
<http://www.pumpstoreusa.com/store/shredderpumps/>
 or call 515-223-4144

For use with nonflammable liquids compatible with pump component materials. Viton® is a registered trademark of E.I. DuPont.

Pump Dimensional & Specification Data

Model	Curve	DIS*	HP	PH	Voltage @ 60 Hz	Full Load Amps	Max Solids (Dia.)	Cord Length (Ft.)	A	B	C [§]	D	W	H	Ship Wt. (Lbs.)
5760-95	A	2	1	1	115	14	1	18 w/plug	5.3 [13.4]	8.9 [22.6]	4.5 [11.4]	5.5 [14.0]	11.4 [28.9]	18.5 [46.9]	50
5761-95				1	230	6									
5762-95				3	230	3									
576B-95				3	460	2									
5763-95	B	3	2	1	230	12	1.1	18	6.5 [16.5]	10.4 [26.4]	5.5 [14.0]	6.5 [16.5]	14.0 [35.3]	21.6 [54.8]	82
5764-95				3	230	6								17.5 [44.4]	68
576C-95				3	460	3								17.5 [44.4]	68
5765-95	C	4	3	1	230	16	1.1	18	7.5 [19.0]	10.4 [26.4]	5.5 [14.0]	6.6 [16.7]	16.2 [40.8]	22.8 [57.9]	120
5766-95				3	230	9								18.9 [48.0]	105
576D-95				3	460	5								18.9 [48.0]	105
5767-95	D	4	5	3	230	14	1.2	32	7.5 [19.0]	10.4 [26.4]	5.5 [14.0]	6.6 [16.7]	16.2 [40.8]	19.7 [50.0]	110
576E-95				3	460	7								19.7 [50.0]	110

(*) Standard NPT (Female) Pipe Thread

NOTE: Dimensions are in inches (centimeters) and have a tolerance of $\pm 1/8$ "

NOTE: Electric supply for ALL motors must be within $\pm 10\%$ of nameplate voltage (Ex: 230V = 203 to 253)

(§) Minimum Liquid Height

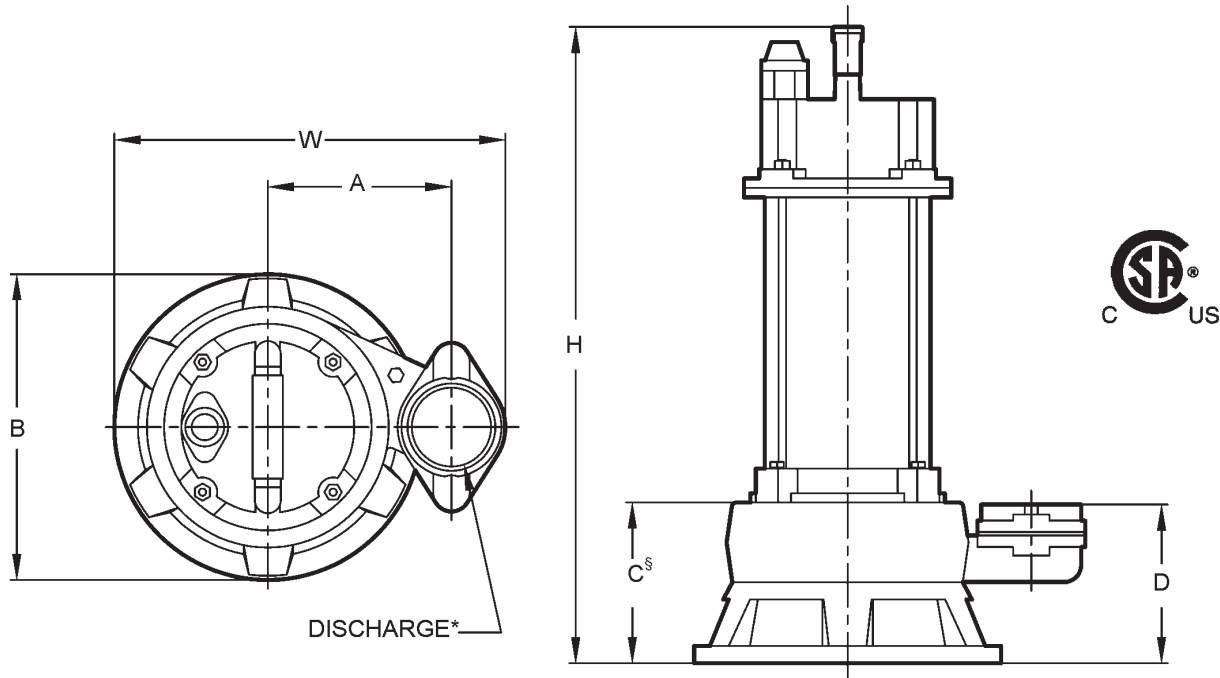

Standard Features

- Cast Iron Construction
- Carbide Tipped Impeller
- Carrying Handle
- Stainless Steel Motor Housing
- UL/CSA Listed
- Maximum Temperature 104° F
- Double Mechanical Seal with Carbide Lower Seal
- Suction Screen
- QSP – Quick Ship Pumps