

Tablet Feeder Models 1000 & 1001

The Simple, Reliable Way to Treat Water/ Wastewater

Severn Trent Services (STS) Models 1000 & 1001 Tablet Feeders are complete, one-piece systems for highly reliable disinfection of treated effluent from any sewage plant having a designed capacity of up to 50,000 GPD. Two tablet feeders in parallel will handle plants with capacities as high as 100,000 GPD. The tablet feeder is used in conjunction with SANURIL® tablets, a disinfecting agent that provides a chemically stable source of chlorine for wastewater disinfection.

Two models are available. Model 1000 with a six-inch pipe inlet, or Model 1001 with solid inlet end for easy field adaptation to the outlets of existing plants. Either tablet feeder can be installed in existing treatment plants where wastewater chlorination is being added or to replace troublesome, unreliable or complicated chlorination systems. Either is equally suitable for factory assembly into new package plants.

Superior Performance at a Lower Cost

Better Performance -- The entire plant flow passes through the tablet feeder where thorough mixing of wastewater with a controlled amount of chlorine takes place. This means more effective disinfection with less bacteria re-growth.

Low Initial Cost -- In addition to low investment in the EIC Tablet Feeder, savings are compounded because no pumps, mixing tanks or costly control devices are required as with most other chlorination systems.

Simple, Low-Cost Installation -- One piece tablet feeder construction requires only inlet piping. No electrical power, wiring, bypasses, or other piping required.

Lower Operating Costs -- The tablet feeder can operate up to 60 days before additional tablets are required for refill. No time-consuming pre-mixing of chemicals or costly cylinder handling. Adding SANURIL tablets is quick and easy. No costs for electrical power or auxiliary power.

Maintenance-Free Operation -- No tanks, pumps, cylinders, external control devices or other moving parts to break down. System is non-mechanical, rust and corrosion proof.



Operating Principle

The STS Tablet Feeder is a one-piece system which operates on the flow-through principle to provide a constant, controlled dosage of chlorine to the effluent of wastewater treatment plants.

The entire flow of treated wastewater passes into the tablet feeder through the inlet pipe. As the stream of water flows past the feed tubes containing the SANURIL tablets, active chlorine is released into the wastewater by the dissolving action of the water stream in contact with the tablets.

Each tablet feeder is furnished with a selection of weir plates, with weirs ranging in size from 1 to 3 inches in width for insertion at the outlet end to control the internal water level, depending upon plant capacity and the residual chlorine required. Each weir plate is calibrated, enabling the user to tell, instantaneously, the flow rate of the plant. The weir in turn automatically controls the chlorine concentration regardless of surges of wastewater flow. As the incoming flow rate increases, the water level in the tablet feeder rises, immersing a greater number of SANURIL tablets. When the incoming flow decreases, the water level in the tablet feeder drops, exposing fewer tablets to the water. Since the amount of SANURIL tablets dissolved depends on the number of tablets immersed in the water, the chlorine concentration remains constant regardless of the rate of waterflow through the tablet feeder.

The chlorinated wastewater then flows into the chlorine contact tank where it is held for the required time to permit effective bacteria killing action.

Each tablet feeder is furnished with four feed tubes. The number of tubes to be filled with SANURIL tablets is determined by the average daily flow-rate and the required residual chlorine content or dosage.

Specifications

The tablet feeder is made of tough, corrosion resistant rotomolded polyethylene. Compact and easy to handle, the tablet feeder measures 26 inches long, 18 inches wide and 16 inches deep. The feed tubes are 24 inches long with an outside diameter of 3 1/2 inches. Each tube holds 29 SANURIL tablets which measure 2-5/8 inches in diameter and are 13/16 of an inch thick. The Model 1000 has a 6 inch diameter inlet pipe size, the Model 1001 has a solid inlet end for easy field adaptation to the outlets of existing plants.

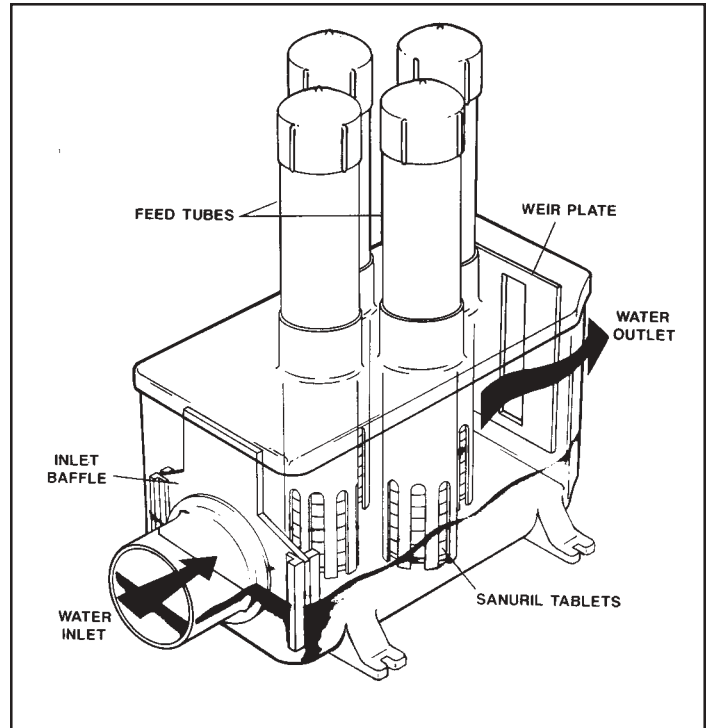

Installation

The EIC Tablet Feeder is designed for installation in any sewage plant having sufficient space to permit mounting. The tablet feeder can be located on or preceding the chlorine contact tank as near as possible to the inlet so as to channel entire plant flow through the tablet feeder before it enters the chlorine contact tank.

Other Applications

In addition to wastewater chlorination, the Model 1000 & 1001 Tablet Feeder can also be used for dechlorination and the chlorination of drinking water. For dechlorination, the Model 1000 & 1001 is used in conjunction with the EIC D-CHLORTM tablets. These tablets are a sodium sulfite based formulation having compatible dimensions for use in the EIC Model 1000 & 1001 Tablet Feeder.

For drinking water chlorination, the Model 1000 & 1001 is used in conjunction with the STS AQUAWARD® chlorinating tablets. The AQUAWARD tablets are a calcium hypochlorite based formulation also having dimensions compatible for use in the STS Model 1000 & 1001 Tablet Feeder. This system is ideal for open channel flow operation and/or remote installations where other methods of disinfection are not practical or economical. For additional information and literature on the D-CHLOR and AQUAWARD Systems, please contact Exceltec.